

**IBC internal cleaner with water drive**

- Cleaning head R55
- 360° spray coverage
- For 600L/800L/1000L/1250L IBC containers (Other sizes on request)
- Water hydraulic motor
- Adjustable speed
- maximum 200 bar
- Maximum 50 liters/minute
- Installation opening IBC -> DN150 / DN225
- INOX 316L / VITON

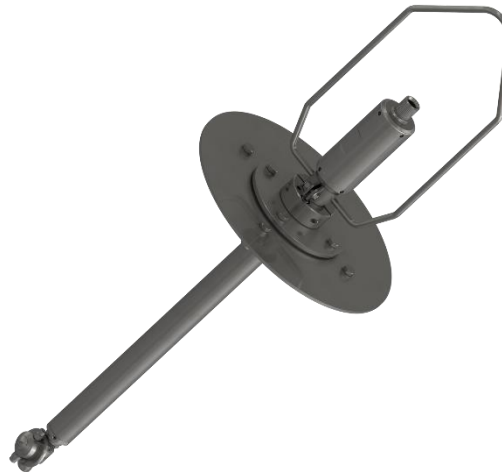

**General description**



The IBC cleaner with water drive consists of a cleaning head, a water drive, a splash guard plate, a connecting pipe and an optional suspension bracket.

The water drive converts the water flow into rotary motion. The connecting pipe transmits this movement and directs the high-pressure water to the spray head. There is a gearing on the spray head which engages with a fixed gearing on the connecting pipe. This causes the spray head itself to rotate by an additional 90°. Due to the rotation in two axes, the nozzles rotate in a spherical shape, whereby all areas in the tank are hit once by the water jet after a certain time.

This modular design means that the individual elements can be replaced and quickly put back into operation if servicing is required.

**Product features**

- Functionality**
  - Using a compact water turbine, the energy from the water is not only used for cleaning, but also to drive the cleaning head.
  - Rotation of cleaning head and cleaning nozzles achieves 360° jet coverage
  - The cleaner can be easily inserted onto the IBC tank using the flange.
- Adjustability**
  - Rotation speed can be varied by means of water volume and can be adapted to different water volumes using different nozzles
  - Guide can be adjusted to opening sizes DN150 and DN225.
- Functional safety**
  - Designed for durability and easy maintenance
  - Very low operating noise
- Variants**
  - The IBC cleaner can be configured for 600L, 800L, 1000L and 1250L containers using different pipe lengths.

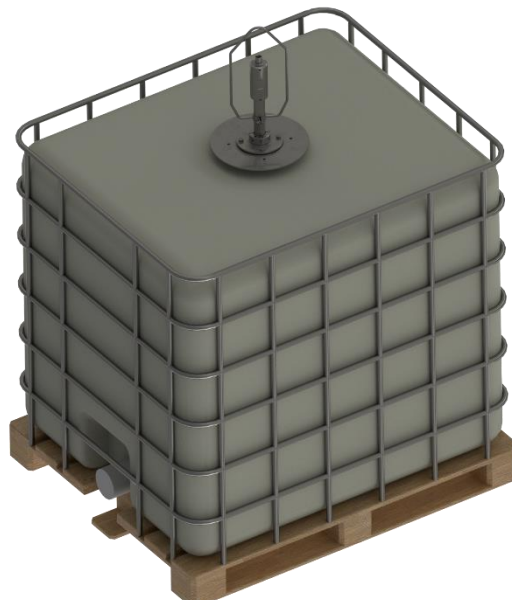

**Technical data**

<b>Drive</b>	water-hydraulic	
<b>Hydraulic data</b>	Minimum pressure	100 bar
	Maximum pressure	200 bar
	Minimum flow rate	10 l/min
	Maximum flow rate	50 l/min
	Spray cover	360°
	Maximum temperature	90 °C
	Connection	M22x1.5 / G1/2" / G3/8"
	Nozzles	2 pieces 0° / 5° / 15° 1/8"
<b>Mechanical data</b>	Speed	10 - 30 revolutions/minute
	Cycle complete	depending on the pollution
<b>Material</b>	Cleaning head	AISI 316 INOX
	Connecting tube	AISI 316 INOX
	Motor	AISI 316 INOX
	Seals	FPM Viton / EPDM / FDA
<b>Installation data</b>	Installation opening	DN150 DN225
	<b>Approvals</b>	CE

**Safety instructions**

- This container interior cleaner is exclusively suitable for cleaning the interior of production, storage and transport containers that can be treated with a high-pressure water jet with cleaning solution.
- The appliance is only intended for use with fresh water and cleaning agents expressly approved by the manufacturer (see [www.moog.ch](http://www.moog.ch)). Always observe the operating conditions and performance limits specified in the technical data sheet.
- This appliance is a technical tool and is not intended for private use. Proper transportation and storage are also prerequisites for its intended use.

**Installation instructions**

**Maintenance** Clean the nozzles with compressed air or with a very thin metal rod if they are clogged with dirt. If necessary, replace the nozzles with similar nozzles with identical nozzle openings.

The filter screen in the inlet of the water-hydraulic drive must be cleaned regularly depending on the degree of soiling of the cleaning medium. A damaged filter screen must be replaced.

On delivery, the speed of the drive is adjusted to the output of the high-pressure supply used according to customer requirements. This can be changed using the three flow control nozzles.

The maintenance intervals vary depending on the duration of use, pressure range, media temperature and cleaning agent used. These must be determined individually during trial operation. The operator is responsible for adhering to the maintenance intervals.

Maintenance must be carried out approximately every 300 operating hours and all seals must be replaced.

The ball bearings must be replaced with original bearings after 2000 operating hours at the latest.

Components

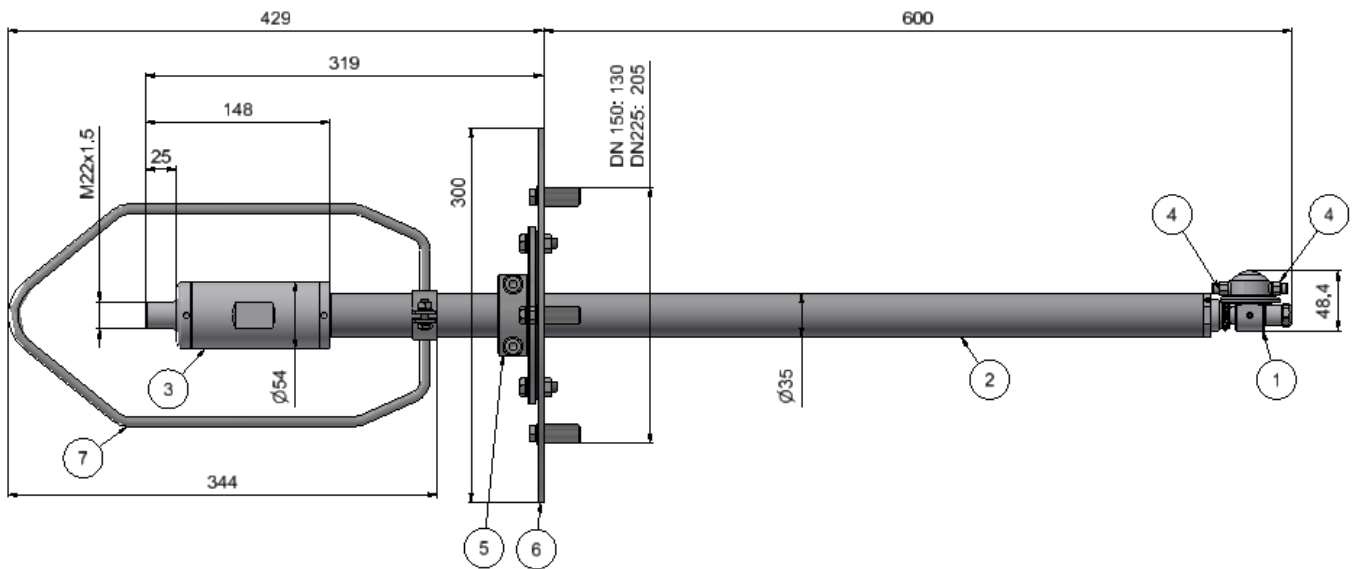

Positions	
Pos.	Component
1	Spray head combination S-R-55
2	Connecting tube Ø35 mm
3	VITON water drive
4	Nozzle cleaning head R55
5	Flange
6	Splash guard
7	Hanger bracket

Accessories

**Accessories and spare parts** Contact Sales +41 31 838 19 19  
 info@moog.ch

Documentations

- Further documentation**
- Operating instructions
  - Spare parts overview
  - Spare parts price list
  - Certificates
  - Declaration of conformity